



iSWM Construction Control Standard Details

Addendum to: **iSWM Technical Manual – Construction Controls**

The following are a selection of 10 iSWM construction control BMP schematics chosen to be provided in standard details.

1. Rock Check Dams
2. Temporary Erosion Control Blankets
3. Dewatering Controls
4. Filter Tube Curb Inlet Protection
5. Hog Wire Weir Curb Inlet Protection
6. Curb Rock Sock On-Grade Curb Inlet Protection
7. Filter Tube Area Inlet Protection
8. Sediment Basin with Overflow Riser
9. Silt Fence
10. Stabilized Construction Exit

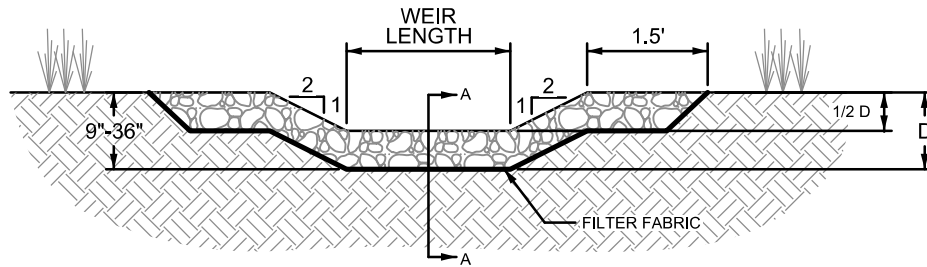

ROCK CHECK DAM VIEW LOOKING UPSTREAM

N.T.S.

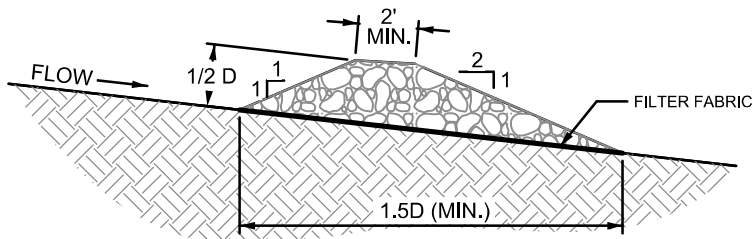

N.T.S.

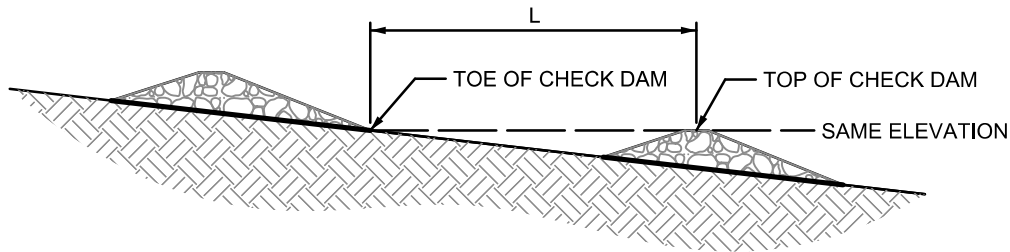

SPACE BETWEEN ROCK CHECK DAMS

N.T.S.

NOTES:

ACTUAL DIMENSIONS OF THE CHECK DAMS SHALL BE DESIGNED BASED ON FLOW CONDITIONS IN THE DRAINAGE SWALE OR DITCH. PROVIDE CALCULATIONS THAT DOCUMENT THE FOLLOWING PARAMETERS USED TO DESIGN THE CHECK DAM.

-HEIGHT OF CHECK DAMS (D) BASED ON SWALE OR DITCH DIMENSIONS AND FLOW CONDITIONS

-SPACING OF CHECK DAMS BASED ON GRADE OF THE SWALE OR DITCH. TOP OF DOWNSTREAM DAM SHALL BE AT THE SAME ELEVATION AS TOE OF UPSTREAM DAM

FIGURE 2.1 STANDARD CONSTRUCTION DETAIL - ROCK CHECK DAMS (1 OF 2)

ROCK CHECK DAM GENERAL NOTES:

1. SEE NCTCOG STANDARD SPECIFICATIONS (2017), SECTION 202.9 CHECK DAM (ROCK).
2. STONE SHALL BE WELL GRADED WITH SIZE RANGE FROM 1 1/2 TO 3 1/2 INCHES IN DIAMETER DEPENDING ON EXPECTED FLOWS.
3. THE CHECK DAM SHALL BE INSPECTED AS SPECIFIED IN THE SWPPP AND SHALL BE REPLACED WHEN THE STRUCTURE CEASES TO FUNCTION AS INTENDED DUE TO SILT ACCUMULATION AMONG THE ROCKS, WASHOUT, CONSTRUCTION TRAFFIC DAMAGE, ETC.
4. WHEN SILT REACHES A DEPTH EQUAL TO ONE-THIRD OF THE HEIGHT OF THE CHECK DAM OR ONE FOOT, WHICHEVER IS LESS, THE SILT SHALL BE REMOVED AND DISPOSED OF PROPERLY.
5. WHEN THE SITE HAS ACHIEVED FINAL STABILIZATION OR ANOTHER EROSION OR SEDIMENT CONTROL DEVICE IS EMPLOYED, THE CHECK DAM AND ACCUMULATED SILT SHALL BE REMOVED AND DISPOSED OF IN AN APPROVED MANNER.

FIGURE 2.1 NOTES ON ROCK CHECK DAM (2 OF 2)

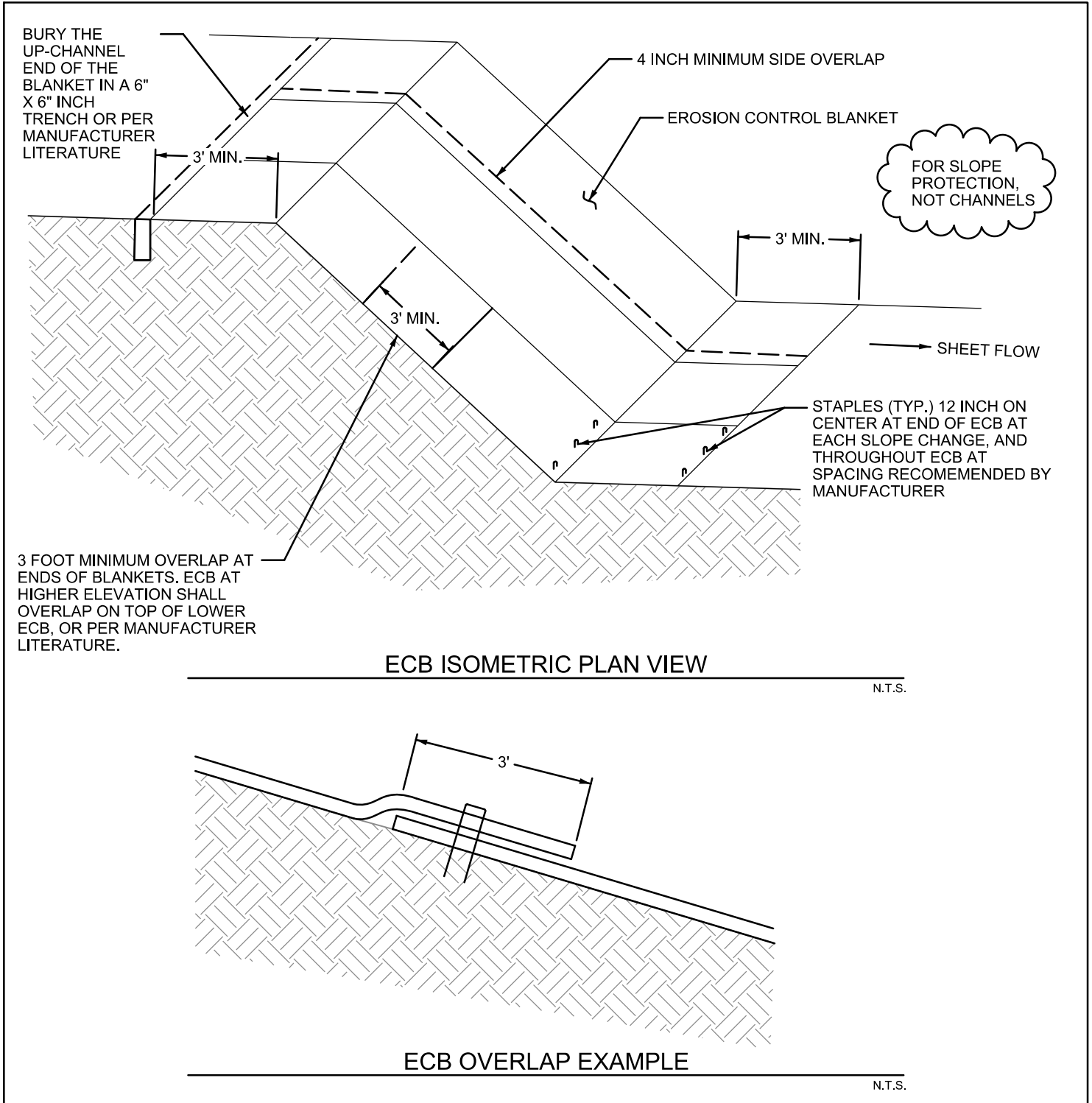
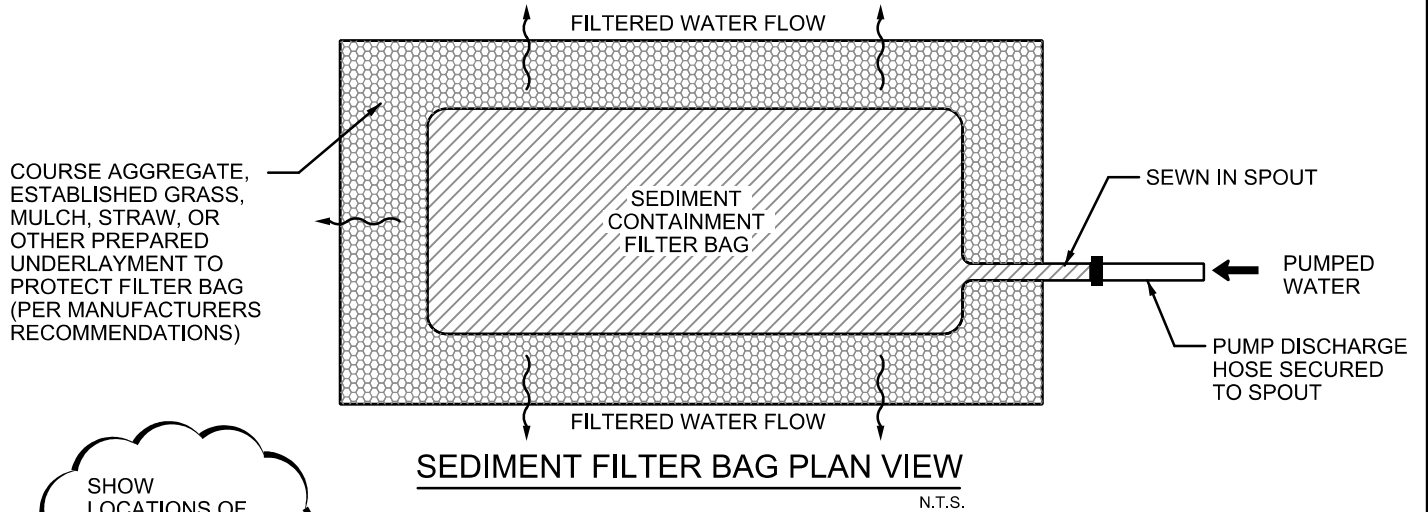

FIGURE 2.7 STANDARD CONSTRUCTION DETAIL - TEMPORARY EROSION CONTROL BLANKETS (1 OF 2)

EROSION CONTROL BLANKETS GENERAL NOTES:

1. SEE NCTCOG STANDARD SPECIFICATIONS (2017) SECTION 202.15.
2. PRIOR TO THE INSTALLATION OF ANY EROSION CONTROL BLANKETS, ALL ROCKS, DIRT CLODS, STUMPS, ROOTS, TRASH AND ANY OTHER OBSTRUCTIONS THAT WOULD PREVENT THE BLANKET FROM LYING IN DIRECT CONTACT WITH THE SOIL SHALL BE REMOVED. ANCHOR TRENCHING SHALL BE LOCATED ALONG THE ENTIRE PERIMETER OF THE INSTALLATION AREA, EXCEPT FOR SMALL AREAS WITH LESS THAN 2% SLOPE.
3. INSTALLATION AND ANCHORING SHALL CONFORM TO THE RECOMMENDATIONS SHOWN WITHIN THE MANUFACTURER'S PUBLISHED LITERATURE FOR THE APPROVED EROSION CONTROL BLANKET. PARTICULAR ATTENTION MUST BE PAID TO JOINTS AND OVERLAPPING MATERIAL.
4. IN ABSENCE OF MANUFACTURE'S LITERATURE, A MINIMUM 11-GUAGE WIRE STAPLES, 6-INCHES IN LENGTH AND 1-INCH WIDTH WILL BE USED.
5. AFTER APPROPRIATE INSTALLATION, THE BLANKETS SHOULD BE CHECKED FOR UNIFORM CONTACT WITH THE SOIL, SECURITY OF THE LAP JOINTS, AND FLUSHNESS OF THE STAPLES WITH THE GROUND.
6. INSPECTION SHALL BE AS SPECIFIED IN THE SWPPP.

FIGURE 2.7 NOTES ON TEMPORARY EROSION CONTROL BLANKETS (2 OF 2)



SHOW LOCATIONS OF FILTER BAGS ON THE DRAWINGS.

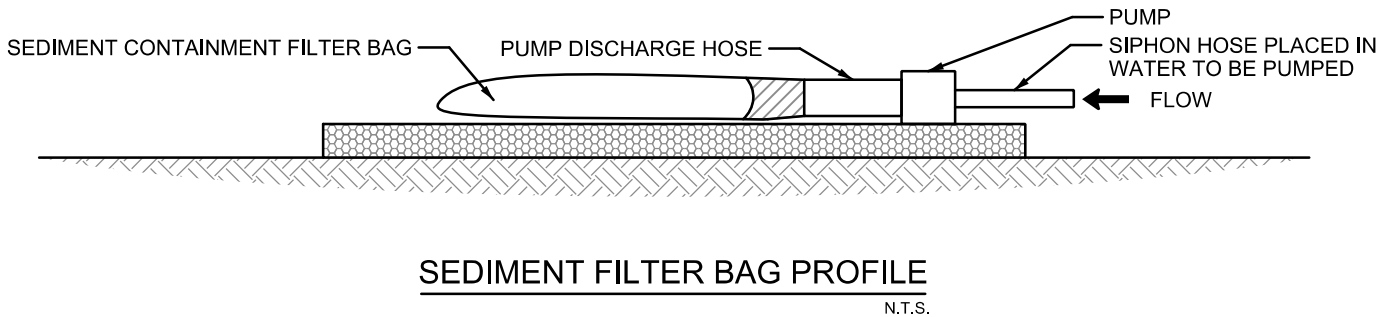

DEWATERING CONTROL GENERAL NOTES:

1. THE BAG SHOULD BE A NON-WOVEN, NEEDLE-PUNCHED, GEOTEXTILE THAT MEETS ASTM CRITERIA-D4632 , D4833, D-3786, D-4355, D-4491, AND D-4751.
2. CAPACITY, INSTALLATION, MAINTENANCE , AND REMOVAL OF BAGS AND PUMPS SHOULD CONFORM TO PUBLISHED MANUFACTURER LITERATURE.

FIGURE 3.4 STANDARD CONSTRUCTION DETAIL - DEWATERING CONTROLS

EXTENDED WRAPPED
FILTER MATERIAL
24" MIN. BEYOND
END OF CURB OPENING
ON BOTH SIDES

1. DOUBLE WRAP OF FLEXIBLE WIRE MESH WITH MESH OPENING 3/4" MAX., OR
2. PLASTIC NETTING DOUBLE WRAPPED WITH 1/2" MAX. OPENING, OR
3. GEOSYNTHETIC TUBES

NOT ALLOWED ON ACTIVE CITY STREETS UNLESS APPROVED BY CITY

NOTE: PLASTIC OR WIRE TIES AROUND WIRE OR PLASTIC MESH EVERY 12"-18" OR MORE AS NEEDED.

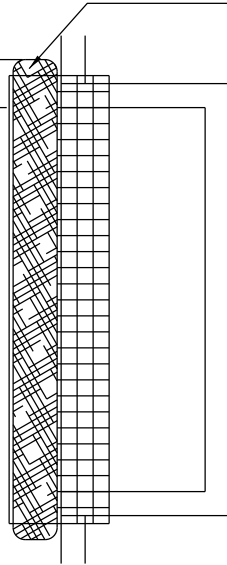

PLAN VIEW

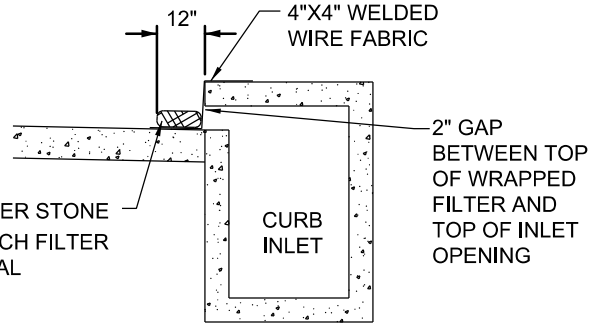

CROSS SECTION

NOTE: VERTICAL PANEL BARRICADES TO BE PLACED WHEN LOCATED ON AN ACTIVE STREET.

TYPE A CURB INLET PROTECTION

EXTENDED WRAPPED
FILTER MATERIAL
24" MIN. BEYOND
END OF CURB OPENING
ON BOTH SIDES

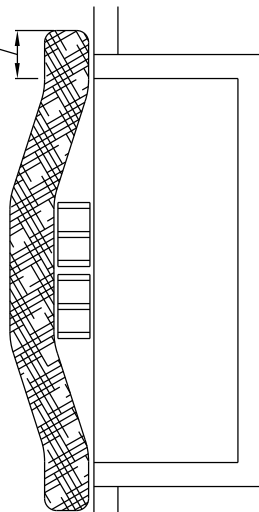

PLAN VIEW

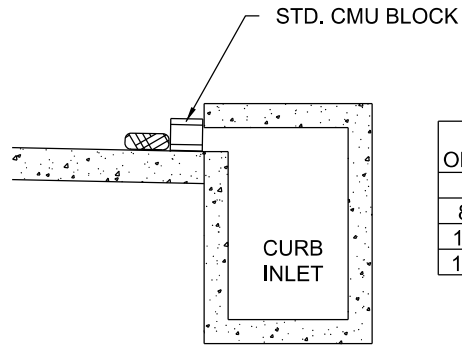

CROSS SECTION

CURB OPENING	MIN. NO. BLOCKS
4'-6'	1
8'-10'	2
12'-14'	3
16'-20'	4

ALTERNATIVE FORM FOR TYPE A CURB INLET PROTECTION

NOTE: SEE NCTCOG STANDARD SPECIFICATIONS (2017), SECTION 202.14 AND 202.18

FIGURE 3.6 STANDARD CONSTRUCTION DETAIL - FILTER TUBE CURB INLET PROTECTION

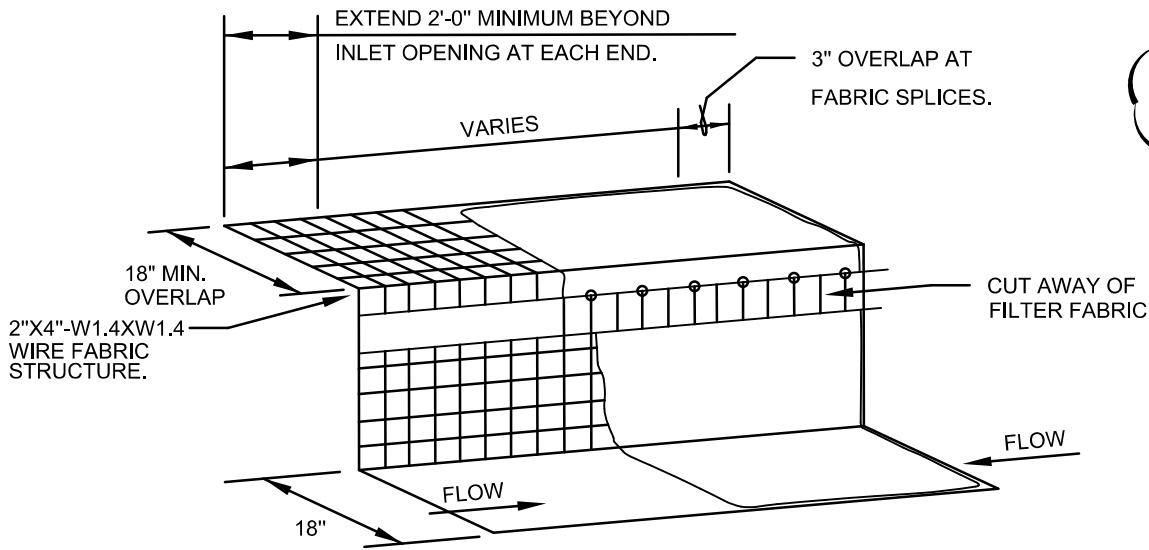

NOT ALLOWED ON ACTIVE CITY STREETS UNLESS APPROVED BY CITY

HOG WIRE WEIR CURB INLET PROTECTION ISOMETRIC VIEW

N.T.S.

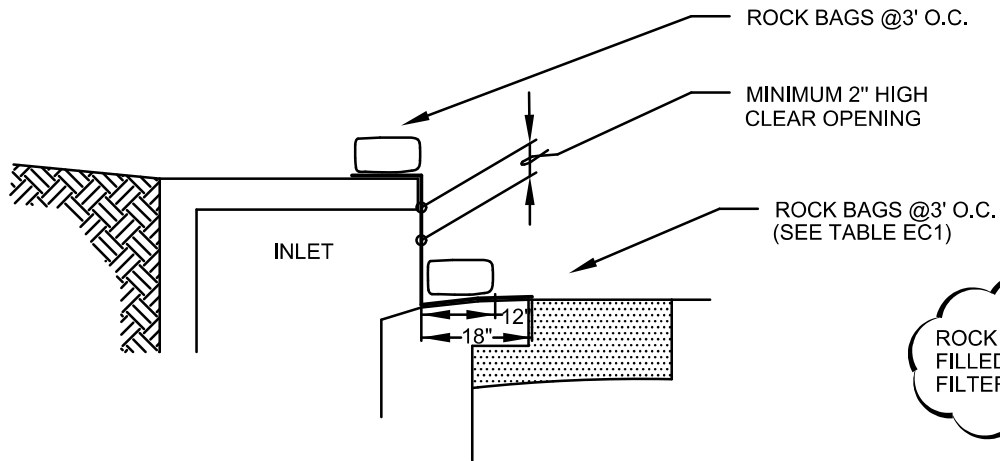

ROCK BAGS FILLED WITH 1 1/2" FILTER STONE

HOG WIRE WEIR CURB INLET PROTECTION CROSS SECTION

N.T.S.

NOTE: THIS CONTROL WILL DECREASE THE CAPACITY OF THE INLET. IT SHALL ONLY BE USED WHEN AN ENGINEER HAS DETERMINED THERE IS ADEQUATE STORAGE OR POSITIVE OVERFLOW.

REFERENCE: NCTCOG STANDARD SPECIFICATIONS (2017), SECTION 202.14

FIGURE 3.7 STANDARD CONSTRUCTION DETAIL - HOG WIRE WEIR CURB INLET PROTECTION (1 OF 2)

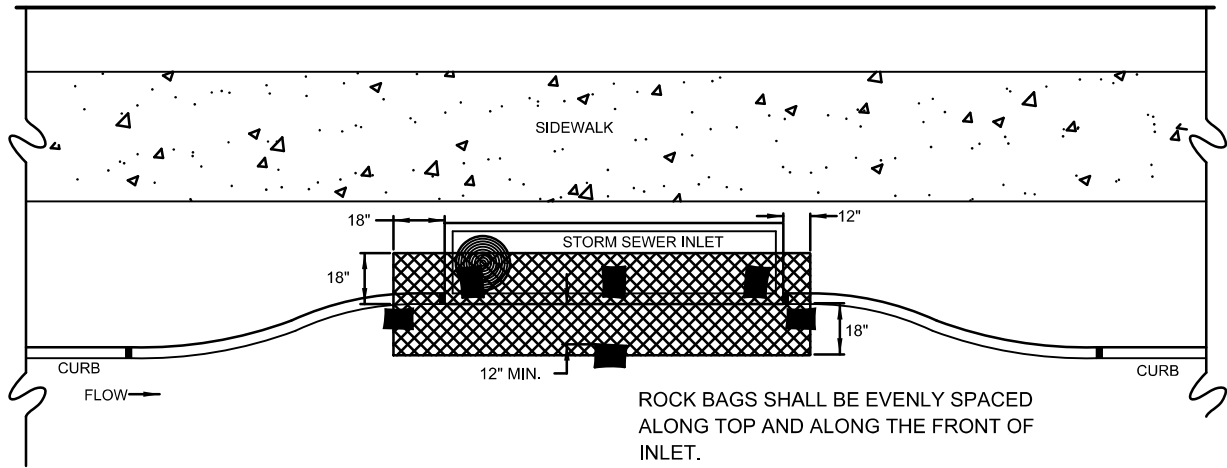

HOG WIRE WEIR CURB INLET PROTECTION PLAN VIEW
N.T.S.

TABLE EC1

INLET OPENING	MINIMUM NUMBER OF ROCK BAGS	
	TOP	FRONT
5'	2	3
10'	3	3
15'	3	4
20'	4	4

NOTES:

1. A SECTION OF FILTER FABRIC SHALL BE REMOVED AS SHOWN ON THIS DETAIL TO PROVIDE A 2" MINIMUM CLEAR OPENING. FABRIC MUST BE SECURED TO WIRE BACKING WITH CLIPS OR HOG RINGS AT THIS LOCATION.
2. INSPECTION SHALL BE MADE BY THE CONTRACTOR AND SILT ACCUMULATION MUST BE REMOVED WHEN DEPTH REACHES 2".
3. INLET PROTECTIONS SHALL BE REMOVED AS SOON AS THE SOURCE OF SEDIMENT IS STABILIZED.

**FIGURE 3.7 STANDARD CONSTRUCTION DETAIL -
HOG WIRE WEIR CURB INLET PROTECTION (2 OF 2)**

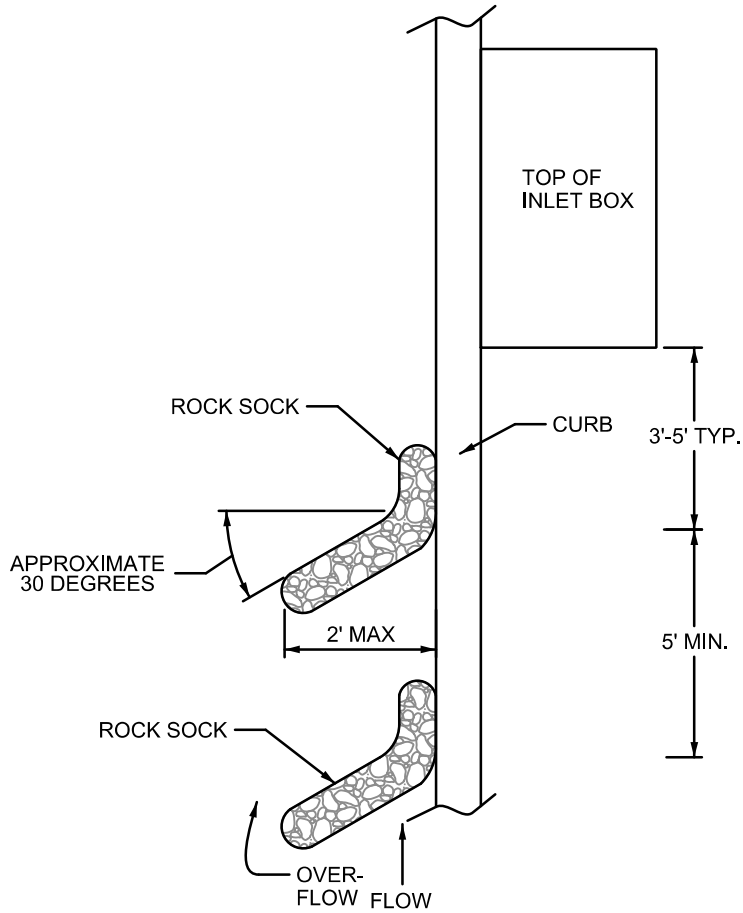

CURB ROCK SOCK ON-GRADE CURB INLET PROTECTION DETAIL

N.T.S.

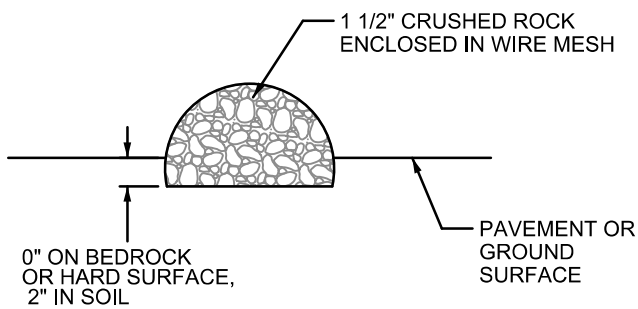

ROCK SOCK SECTION

N.T.S.

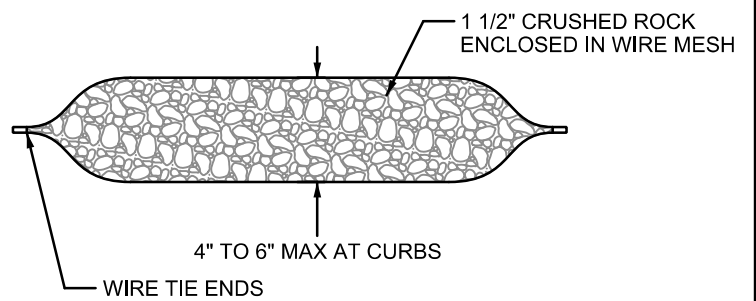

ROCK SOCK PLAN

N.T.S.

FIGURE 3.9 STANDARD CONSTRUCTION DETAIL - CURB ROCK SOCK ON-GRADE CURB INLET PROTECTION (1 OF 2)

CURB ROCK SOCK ON-GRADE CURB INLET PROTECTION GENERAL NOTES:

1. THIS DETAIL IS INTENDED FOR USE WITH ON-GRADE INLETS (NOT A LOW POINT) TO TRAP SEDIMENT.
2. DO NOT INSTALL ON INLETS WHERE THE ROCK SOCKS WOULD EXTEND INTO AN ACTIVE TRAVEL LANE.
3. ROCK SOCKS MAY BE USED ON PAVED OR UNPAVED SURFACES.
4. MAXIMUM ROCK SOCK DIAMETER 4" TO 6".
5. MINIMUM OF 2 CURB ROCK SOCKS.

**FIGURE 3.9 STANDARD CONSTRUCTION DETAIL -
CURB ROCK SOCK ON-GRADE CURB INLET PROTECTION (2 OF 2)**

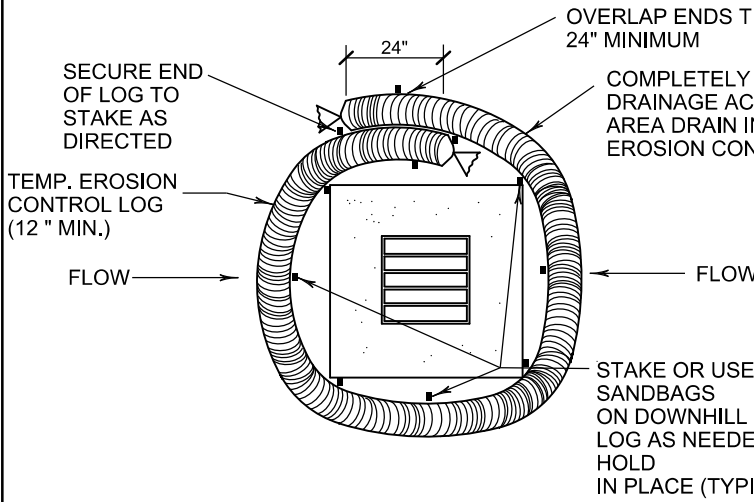

FILTER TUBE AREA INLET PROTECTION PLAN VIEW

N.T.S.

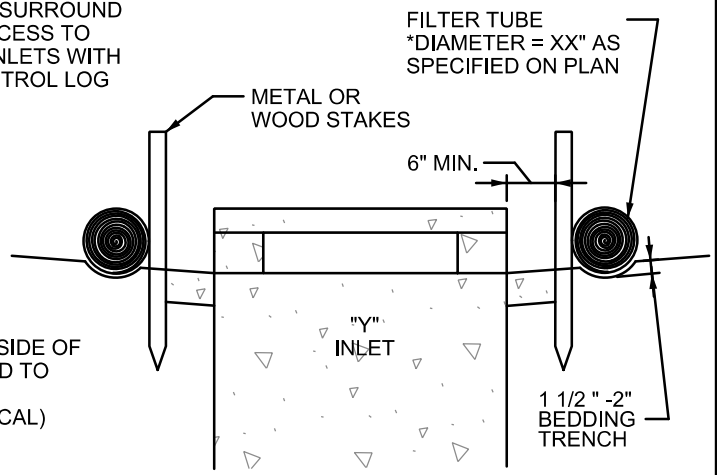

FILTER TUBE "Y" INLET PROTECTION CROSS SECTION

N.T.S.

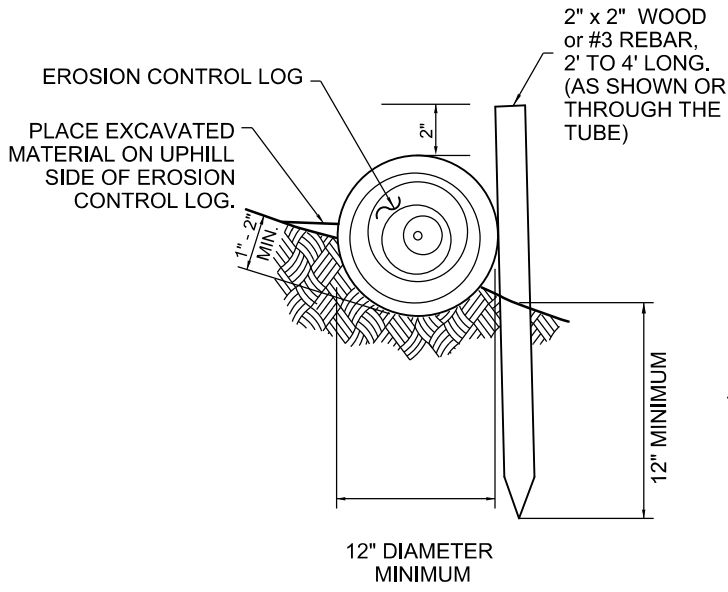

EMBEDMENT EXAMPLE FOR FILTER TUBE

N.T.S.

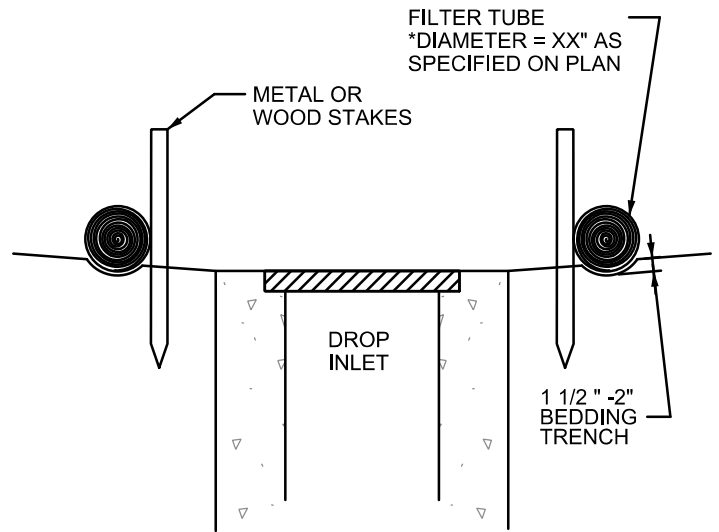

FILTER TUBE DROP INLET PROTECTION CROSS SECTION

N.T.S.

NOTE: SEE NCTCOG STANDARD SPECIFICATIONS (2017), SECTION 202.18

FIGURE 3.13 STANDARD CONSTRUCTION DETAIL - FILTER TUBE AREA INLET PROTECTION

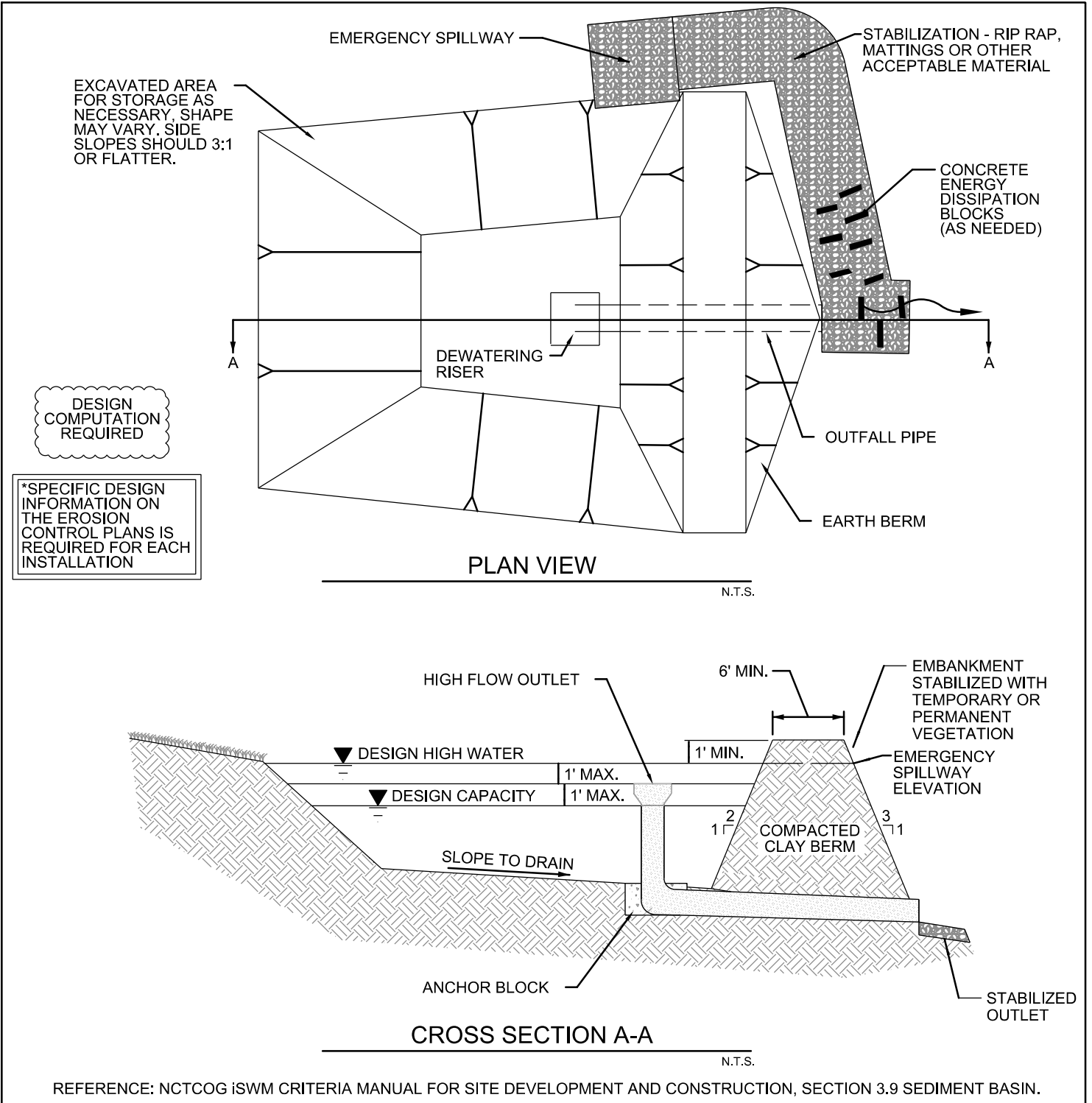
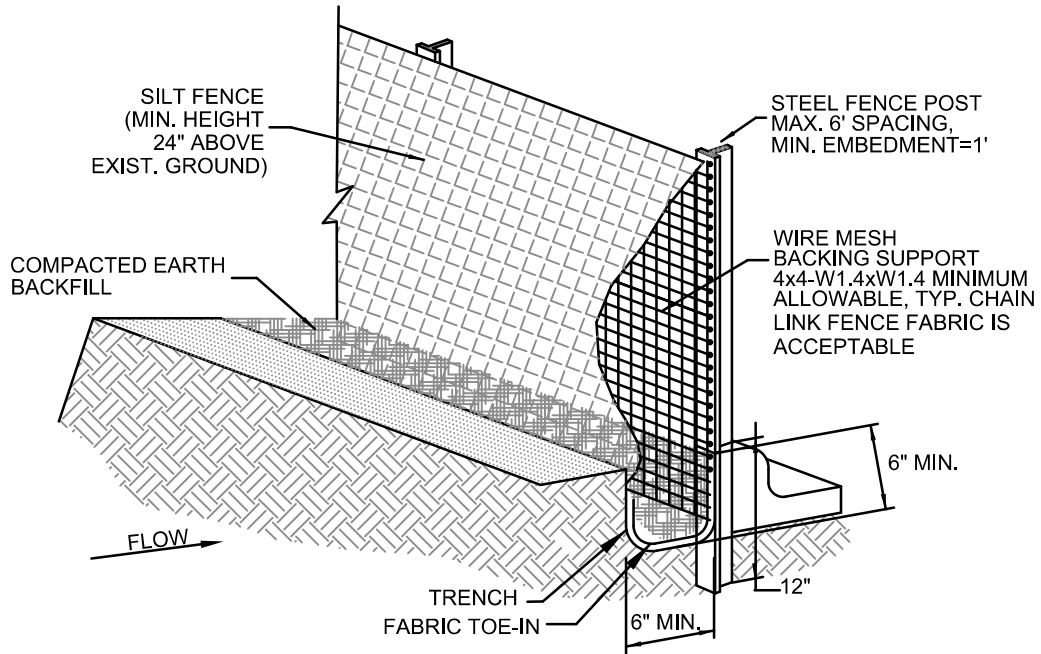
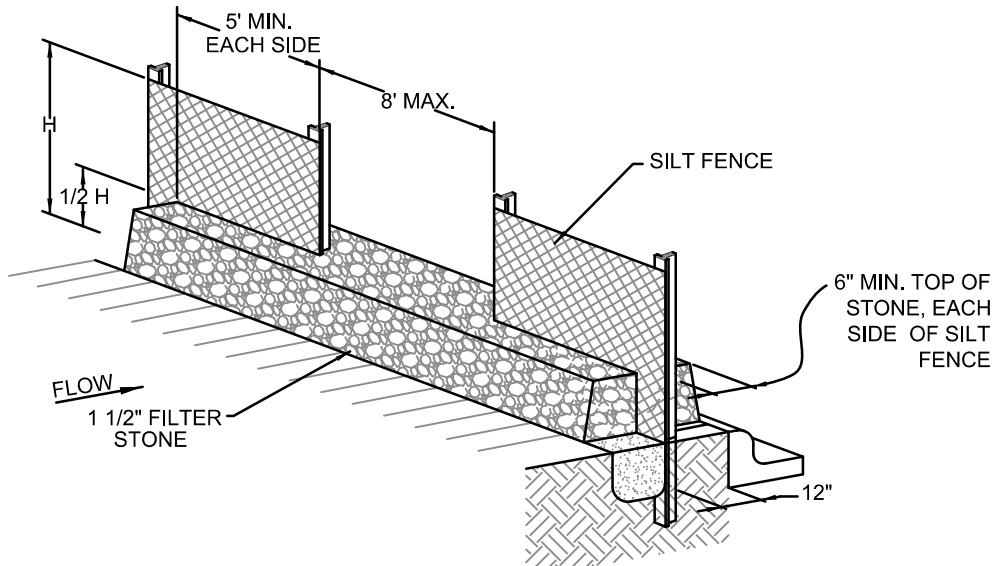

FIGURE 3.20 STANDARD CONSTRUCTION DETAIL -
SEDIMENT BASIN WITH OVERFLOW RISER



ISOMETRIC PLAN VIEW

N.T.S.



SILT FENCE OVERFLOW STRUCTURE

N.T.S.

FIGURE 3.28 STANDARD CONSTRUCTION DETAIL - FOR SILT FENCE (1 OF 2)

SILT FENCE GENERAL NOTES:

1. DESIGN SHALL SHOW ON THE DRAWINGS THE LOCATIONS WHERE OVERFLOW STRUCTURES SHALL BE INSTALLED. OVERFLOW STRUCTURES ARE REQUIRED AT ALL LOW POINTS AND AT A SPACING OF APPROXIMATELY 300 FEET WHERE NO LOW POINT IS APPARENT.
2. DESIGNER SHALL SHOW ON THE DRAWINGS THE LOCATIONS WHERE SILT FENCE IS TO BE TURNED UPSLOPE AT THE ENDS. UPSLOPE LENGTHS SHALL BE A MINIMUM OF 10 FEET.
3. POST WHICH SUPPORT THE SILT FENCE SHALL BE INSTALLED ON A SLIGHT ANGLE TOWARD THE ANTICIPATED RUNOFF SOURCE. POST MUST BE EMBEDDED A MINIMUM OF ONE FOOT.
4. THE TOE OF THE SILT FENCE SHALL BE TRENCHED IN WITH A SPADE OR MECHANICAL TRENCHER, SO THAT THE DOWNSLOPE FACE OF THE TRENCH IS FLAT AND PERPENDICULAR TO THE LINE OF FLOW.
5. THE TRENCH MUST BE A MINIMUM OF 6 INCHES DEEP AND 6 INCHES WIDE TO ALLOW FOR THE SILT FENCE FABRIC TO BE LAID IN THE GROUND AND BACKFILLED WITH COMPACTED MATERIAL.
6. SILT FENCE SHOULD BE SECURELY FASTENED TO EACH SUPPORT POST OR TO WIRE BACKING, WHICH IN TURN IS ATTACHED TO THE FENCE POST. THERE SHALL BE A 3 FOOT OVERLAP, SECURELY FASTENED WHERE ENDS OF FABRIC MEET.
7. INSPECTION SHALL BE AS SPECIFIED IN THE SWPPP. REPAIR OR REPLACEMENT SHALL BE MADE PROMPTLY AS NEEDED.
8. SILT FENCE SHALL BE REMOVED WHEN FINAL STABILIZATION IS ACHIEVED OR ANOTHER EROSION OR SEDIMENT CONTROL DEVICE IS EMPLOYED.
9. ACCUMULATED SILT SHALL BE REMOVED WHEN IT REACHES A DEPTH OF HALF THE HEIGHT OF THE FENCE. THE SILT SHALL BE DISPOSED OF AT AN APPROVED SITE AND IN SUCH A MANNER AS TO NOT CONTRIBUTE TO ADDITIONAL SILTATION.
10. SEE NCTCOG STANDARD SPECIFICATIONS (2017), SECTION 202.5

FIGURE 3.28 NOTES FOR SILT FENCE (2 OF 2)

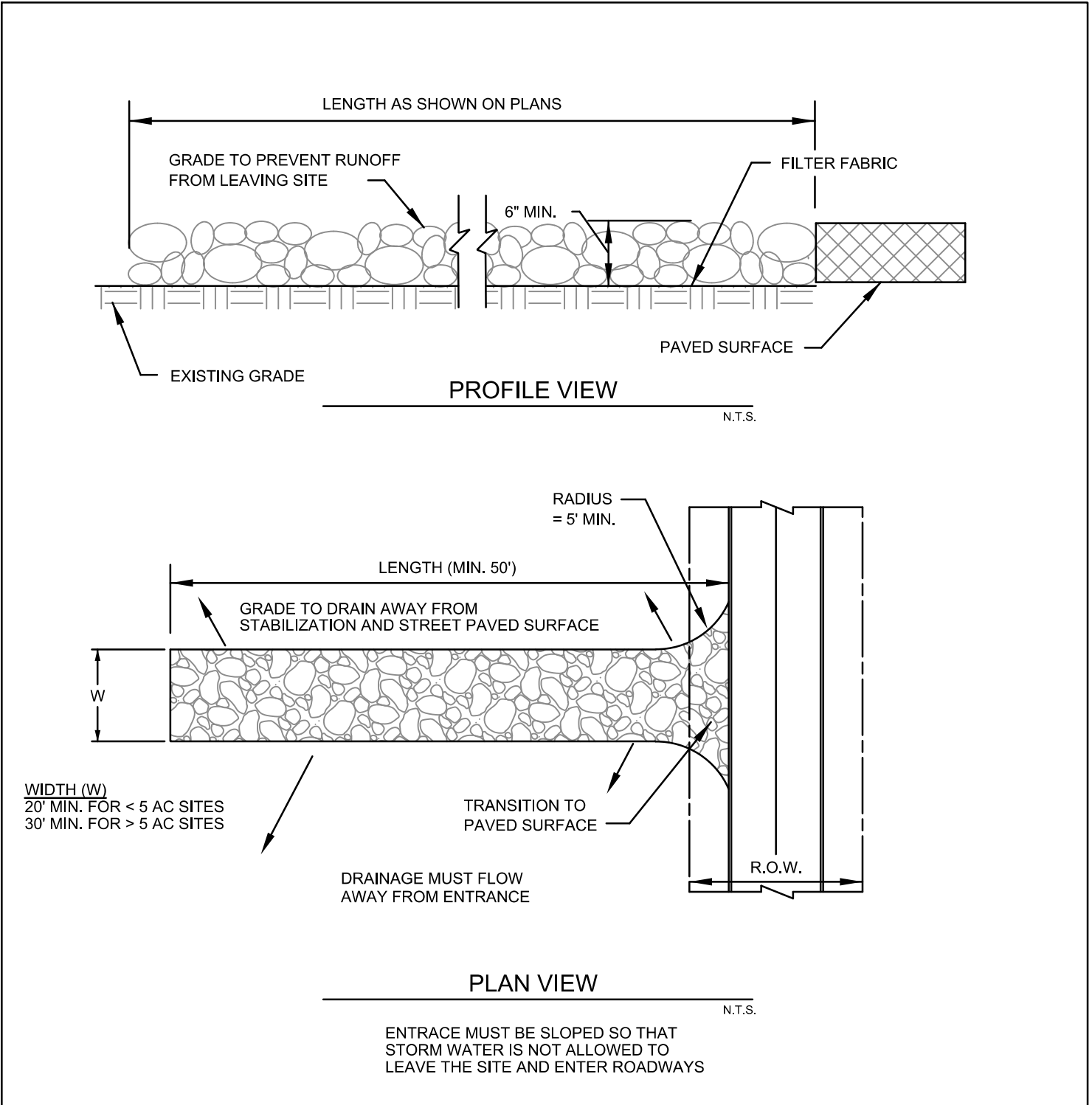

FIGURE 3.29 STANDARD CONSTRUCTION DETAIL - STABILIZED CONSTRUCTION EXIT (1 OF 2)

STABILIZED CONSTRUCTION ENTRANCE GENERAL NOTES:

1. SEE NCTCOG STANDARD SPECIFICATIONS (2017), SECTION 202.11
2. THE THICKNESS SHALL NOT BE LESS THAN 6 INCHES.
3. STONE SHALL BE 3 TO 5 INCH DIAMETER COURSE AGGREGATE, NO CRUSHED PORTLAND CEMENT CONCRETE ALLOWED.
4. LENGTH SHALL BE SHOWN ON PLANS, WITH A MINIMUM LENGTH OF 50 FEET.
5. THE WIDTH SHALL BE NO LESS THAN 20' FOR SITES LESS THAN 5 AC, AND 30' FOR SITES GREATER THAN 5 AC, AT ALL POINTS OF INGRESS OR EGRESS.
6. WHEN NECESSARY, VEHICLES SHALL BE CLEANED TO REMOVE SEDIMENT PRIOR TO ENTRANCE ONTO A PUBLIC ROADWAY. WHEN WASHING IS REQUIRED, IT SHALL BE DONE ON AN AREA STABILIZED WITH CRUSHED STONE WITH DRAINAGE FLOWING AWAY FROM BOTH THE STREET AND THE STABILIZED ENTRANCE. ALL SEDIMENT SHALL BE PREVENTED FROM ENTERING ANY STORM DRAIN, DITCH OR WATERCOURSE USING APPROVED METHODS.
7. THE ENTRANCE SHALL BE MAINTAINED IN A CONDITION WHICH WILL PREVENT TRACKING OR FLOWING OF SEDIMENT ONTO PAVED SURFACES. THIS MAY REQUIRE PERIODIC TOP DRESSING WITH ADDITIONAL STONE AS CONDITIONS DEMAND. ALL SEDIMENT SPILLED, DROPPED, WASHED, OR TRACKED ONTO PAVED SURFACES MUST BE REMOVED IMMEDIATELY.
8. THE ENTRANCE MUST BE PROPERLY GRADED OR INCORPORATE A DRAINAGE SWALE TO PREVENT RUNOFF FROM LEAVING THE CONSTRUCTION SITE.
9. INSPECTION SHALL BE SPECIFIED IN THE SWPPP.

FIGURE 3.29 NOTES FOR STABILIZED CONSTRUCTION EXIT (2 OF 2)